

Mewis Duct[®] – New Developments, Solutions and Conclusions

Friedrich Mewis¹, Thomas Guiard²

¹Mewis Ship Hydrodynamics (MSH), Dresden, Germany

²IBMV Maritime Innovationsgesellschaft (IBMV), Rostock, Germany

ABSTRACT

The reduction of fuel consumption has become a major concern for ship owners. The most effective measure for reducing the fuel consumption is the installation of a so-called Energy Saving Device (ESD) near the propeller with the aim of improving the overall propulsive efficiency. There are several solutions on the market.

At the SMP09, the Mewis Duct[®] (MD) was introduced as a novel type of ESD in its first stage of development and realisation. Since then, more than 20 MDs have been installed in different vessels.

The MD design and optimisation method was improved and streamlined by making use of the collected experience of the CFD-based pre-optimisation process, the model test results, and full scale measurements. Model tests were performed for several projects in different tanks worldwide. These consisted primarily of resistance and propulsion tests with and without the MD fitted, and in some cases, separate cavitation and manoeuvring tests. In general, the results have been very successful; the MD not only reduces the required power by up to 8 % with a mean saving averaged over 35 tests of 6.5 %, but also significantly reduces the vibration excitation by reducing pressure pulses by up to 80 %. The cavitation behaviour of the propeller is positively affected, and the MD tends to improve the course stability of unstable vessels.

The entire development of the Mewis Duct[®] was only possible through the consistent and careful use of CFD-tools in combination with the expertise of experienced naval architects and hydrodynamicists.

A part of this paper gives a small impression of the simulation-based design process of the Mewis Duct[®].

The Mewis Duct[®] has been developed in cooperation with Becker Marine Systems, Hamburg (BMS). All CFD-calculations were carried out by IBMV, Rostock. BMS is marketing and selling the Mewis Duct[®].

Keywords

Energy saving devices, power reduction, CFD-methods, Contra-Propeller-Principle, Pre-Duct-Principle, Mewis Duct[®], Cavitation, Course stability

1 INTRODUCTION

Energy Saving Devices (ESDs) are stationary flow-directing devices positioned near the propeller. These can be positioned either ahead of the propeller, fixed to the ship's hull, or behind, fixed either to the rudder or the propeller itself.

Power-saving devices that improve propulsion efficiency have been in use for over 100 years; for example, Wagner (1929) reports on 25 years' experience with the contra-rotating propeller principle.

Well-known devices for reducing the wake losses are the WED (Wake Equalising Duct), see Schneekluth (1986); and the SILD (Sumitomo Integrated Lammeren Duct) as detailed in Sasaki & Aono (1997). These devices are based on an idea of Van Lammeren (1949).

Devices for reducing the rotation losses include the SVA fin system (Mewis & Peters 1986), the Daewoo Pre Swirl System, PSS (Lee et al 1992), and the Hyundai Thrust Fin system which is fitted to the rudder, see Hyundai (2005). A well-known solution to reducing the losses in the propeller hub vortex is the PBCF (Propeller Boss Cap Fins) (Ouchi et al 1990). The Kappel propeller utilises a special tip fin integrated into the propeller blades to reduce the tip vortex losses, see Andersen et al (2000).

It is clear that there exist many energy-saving devices on the market, each with extensive in-service and model testing experience. So it would appear to be impossible to develop an absolutely new solution to the problem. However, by combining two or more components of already established principles, new developments are possible. This approach offers even more possibilities by targeting a combination of types of flow losses.

The Mewis Duct[®] described in this paper is such a combination, which is based on two fully independent

working ESD-Principles:

- The Contra-Propeller-Principle, well known for more than 100 years, see Wagner (1929), and
- The Pre-Duct-Principle, first published in 1949 by Van Lammeren, see Figures 1 and 2.

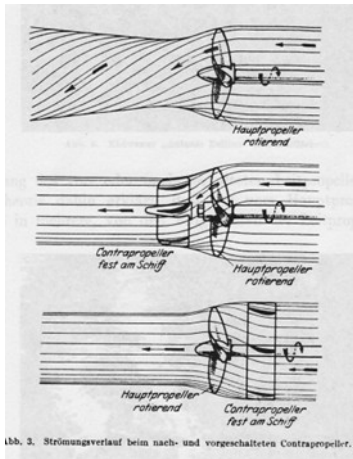

Figure 1: Wagner (1929), Explanation of the Contra-Propeller-Principle

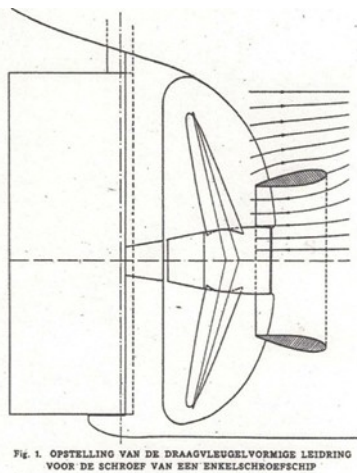

Figure 2: Van Lammeren (1949), Explanation of the Pre-Duct-Principle

2 SHORT DESCRIPTION OF THE MEWIS DUCT®

The design goal of the Mewis Duct®, in comparison with other ESDs, is to improve two fully independent loss sources, namely:

- Losses in the ships wake by the duct, and
- Rotational losses in the slipstream by the fins.

The key advantage of the Mewis Duct® is to improve four components of the propeller flow:

- Equalisation of the propeller inflow by positioning the duct ahead of the propeller. The duct axis is positioned vertically above the propeller shaft axis, with the duct diameter smaller than the propeller diameter. The duct is

stabilising the fin effect as well as producing thrust.

- Reduction of rotational losses in the slipstream by integrating a pre-swirl fin system within the duct. The chord length of the fin profiles is smaller than the duct chord length, with the fins positioned towards the aft end of the duct. The duct itself acts as a type of endplate to the fins, thus increasing their effectiveness.
- An additional small improvement of the propulsion efficiency is obtained from higher loads generated at the inner radii of the propeller which leads to a reduction of the propeller hub vortex losses; this effect increases with increasing hub to propeller diameter ratio.
- A further small power reduction results from the improvement of the cavitation behaviour at the propeller blade tips.

Figure 3 shows the general arrangements of the Mewis Duct®, Figures 4 and 5 show the pre-duct and pre-swirl fin system components, respectively.

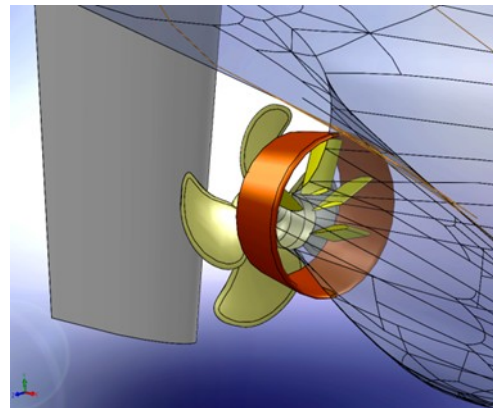

Figure 3: Mewis Duct® propeller right-handed turning, view diagonal from ahead/starboard, simplified picture

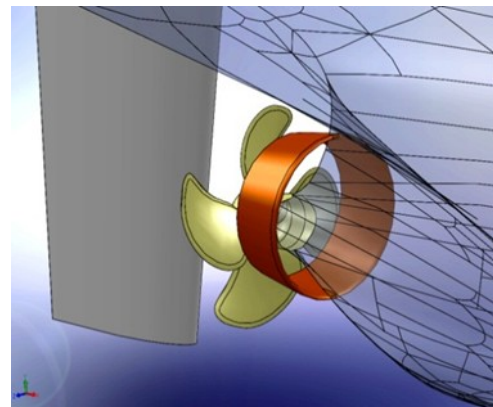

Figure 4: Mewis Duct®-Components, the pre-duct

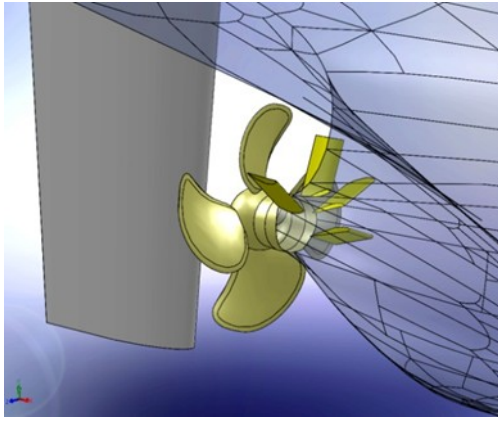

Figure 5: Mewis Duct®-Components, the pre-swirl fin system

The pre-estimation of expected power reductions by ESDs is possible only on the basis of a careful analysis of losses around the running propeller behind the ship. There is one important rule: You can recover no more than the existing losses.

Figure 6 shows the possible power reductions by the MD based on these loss analyses. The solid black line represents the theoretical calculated power reduction, but the real possibilities depend on more realistic conditions, such as the quality of the wake field of the ship (see also Chapter 9), the propeller type and design quality, and the quality of the MD's design itself. All these factors lead to a scattering of about $\pm 2\%$ to the basic line.

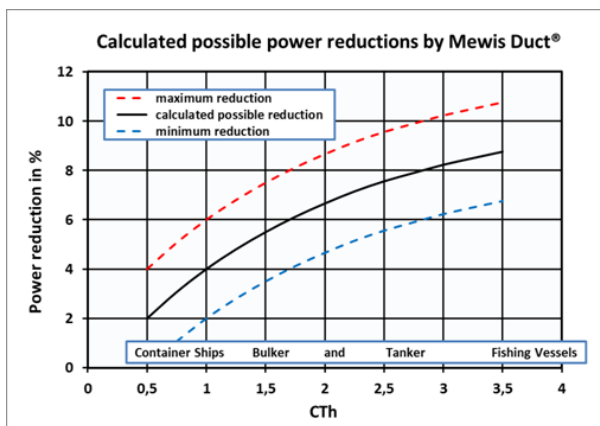

Figure 6: Possible power reductions by Mewis Duct®, calculated on base of a loss analysis

3 FULL SCALE INSTALLATIONS

Up to the end of January 2011, sixteen full scale Mewis Ducts® have been installed on six different ship types, retrofits as well as new buildings. About 80 further MDs for 14 different ship types are on order.

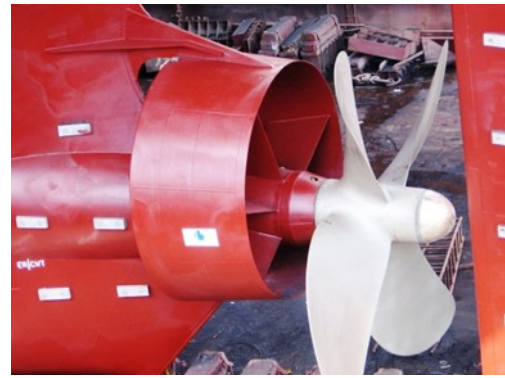

Figure 7: First installed full scale Mewis Duct®, STAR ISTIND, 54,000 tdw MPC, September 2009

4 FULL SCALE TRIAL RESULTS

New full scale trial measurements without and with the Mewis Duct® have been undertaken in October 2010 for a 57,000 tdw bulk carrier new building, AS VINCENTIA, within 5 days of each other and under ideal comparable conditions. After the usual shipyard trials trip, the ship went back in the dock for installation of the MD. Five days later the ship then carried out additional trials at the same sea location. Compared to the original set of trials the weather and ship conditions were virtually identical, with only a small 5 cm difference in loading condition.

Figures 8 and 9 show the full scale trial results and the model scale trial prognosis for the 57,000 tdw bulk carrier AS VINCENTIA without and with Mewis Duct®.

The results are compared at the contractual speed of 14.4 knots:

Full scale: 6.5 % power reduction or 0.25 knots higher speed at constant power, Propeller speed 0.8 % increased

Model scale: 7.1 % power reduction or 0.27 knots higher speed at constant power, Propeller speed 0.9 % decreased

The measured power savings can be called identical, the difference of 0.6 % lies within the range of the overall measurement accuracy.

The change of the propeller speed in full scale does not affect the model scale prognosis; while the propeller speed was decreased in model scale, it was increased in full scale by about one percent each. To date, an explanation for that difference has not been found.

An additional side result is that the trials prognosis of HSVA without and with Mewis Duct® matches very well with the full scale results, the absolute figures of power, as well as the power difference and its tendency.

The measurements were carried out by MARIN; the final analysis was done by HSVA, where the original model tests were performed.

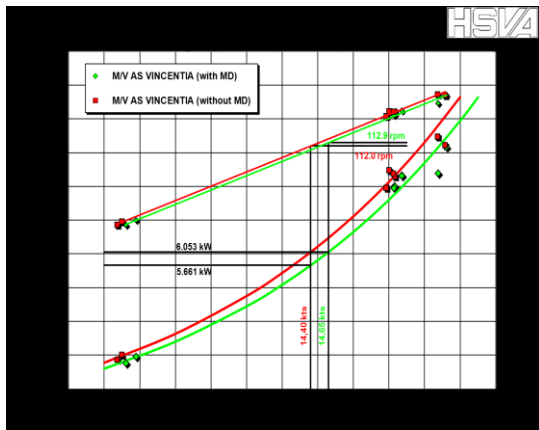

Figure 8: Full scale trial results without and with Mewis Duct®, AS VINCENTIA, power reduction: 6.5 % at contract speed 14.4 kts

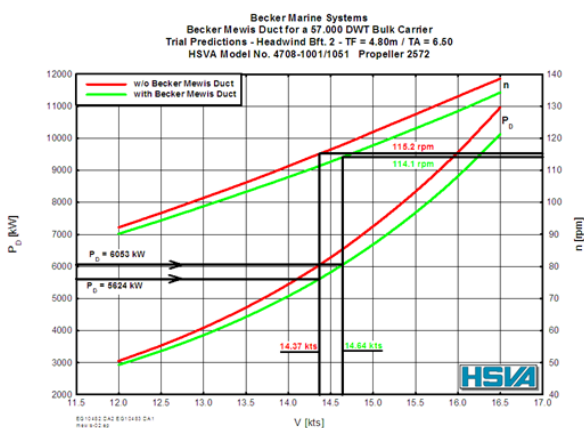

Figure 9: Model test results without and with Mewis Duct®, AS VINCENTIA, power reduction: 7.1 % at contract speed 14.4 kts

5 FULL SCALE OBSERVATIONS OF CAVITATION AND VIBRATION BEHAVIOR

On the first vessel to be fitted with a Mewis Duct®, the STAR ISTIND, (see Figure 7), an observation window was installed above the propeller and MD for observation of the cavitation behaviour. These observations were started with the installation of the MD, so no comparison of the propeller cavitation behaviour is possible. But two results are very important: There is no cavitation at the Mewis Duct®; and no cavitation at the blade roots of the propeller.

Regarding vibration behaviour for this vessel, unfortunately no measurement data are available; but, there is crew feedback from nearly all ships retrofitted with MDs reporting that the vibrations are significantly lower, especially at ballast draughts.

There is one more remarkable observation regarding the engine behaviour in seaway with and without Mewis Duct®. It seems to be that the MD stabilises the propeller revolutions in heavy seaways; this observation was made on different ships of one particular type, each of which

have experienced engine problems prior to installation of the Mewis Duct®s.

6 MODEL SCALE SELF PROPULSION TEST RESULTS

From the outset of the development of the Mewis Duct®, Becker Marine Systems decided to undertake ship model tests for the initial projects to be sure of the expected power reductions. This decision was done with two targets: first, the estimation of the actual power savings; and second, the collection of data for the validation of CFD-results, with the aim of improving the understanding and procedural aspects to allow only CFD-techniques to be used in the future.

By the end of January 2011 self-propulsion tests to estimate the power savings by the Mewis Duct® have been carried out for 18 different projects in 6 different model tanks, namely HSVA (8), SVA (3), SSPA (3), MARINTEK (2), HMRI (1), and MARIN (1). There are nearly no differences in the results from one tank to the other.

The ship types include the range from a 12,000 tdw bulk carrier to a 320,000 tdw VLCC Tanker, and also a 20-knot RoRo vessel ($C_{Th} = 1.1$).

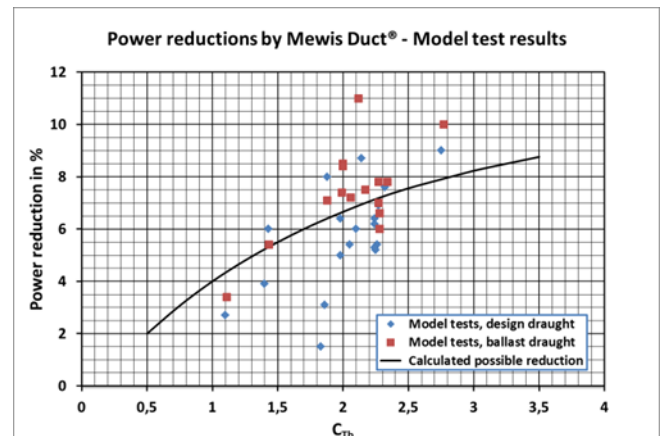

Figure 10: Power reductions by Mewis Duct®, model test results, average measured power reduction: 6.5 %

The results of all 35 model tests with and without MD are summarised in Figure 10, the average of all measurements is 6.5 % power reduction by the Mewis Duct®.

Average design draught: 5.7 % power reduction

Average ballast draught: 7.3 % power reduction

The difference between design and ballast draught is higher than theoretically expected. This may be due to two reasons:

- Firstly, that in general, the ship lines for the ballast condition are, from a hydrodynamic point of view, less optimal compared to the design draught condition since the ship lines are optimised for the design draught. In other words, in the ballast condition the flow losses are higher,

and therefore this condition is more amenable to improvement through the use of ESDs.

- Secondly, that in a few cases the measured power difference in model tests is affected by flow separations in ballast draught, which are reduced or eliminated by the MD. These flow separations normally do not occur in full scale.

If the power gain has to be proved in full scale at ballast draught, this circumstance can lead to significant problems for the MD-seller since, by consistent usage of the standard procedure for estimation of the achieved power reduction at design draught based on ballast draught measurements in full scale, the method may lead to wrong results at the design draught.

7 MODEL SCALE CAVITATION TEST RESULTS

Model tests for the estimation of the influence of the Mewis Duct[®] on the cavitation behaviour and pressure pulse excitement were carried out for two different ship types at two different towing tanks (SSPA and HSVA). The test results are very similar. Figures 11 and 12 show the results of cavitation observations from a model of a 158,000 tdw bulk carrier, fitted with and without Mewis Duct[®]. It can be seen that the blade tip cavitation is significantly reduced by the MD. This leads to a further small power reduction when using an existing propeller. For a new building with a MD fitted, the propeller could be designed with a better load distribution with the result of slightly higher propeller efficiency.

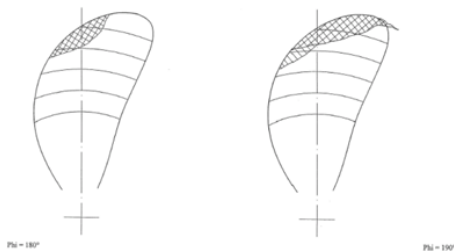

Figure 11: Cavitation behaviour without Mewis Duct[®], 158,000 tdw Bulker, HSVA, on the left 190° blade turning angle, on the right 200°

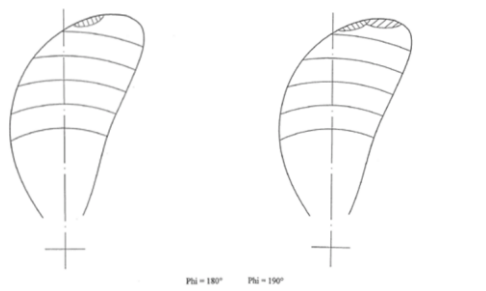

Figure 12: Cavitation behaviour with Mewis Duct[®], 158,000 tdw Bulker, HSVA, on the left 190° blade turning angle, on the right 200°

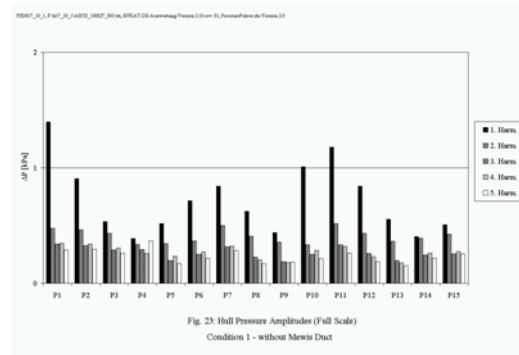

Figure 13: Pressure pulses above propeller without Mewis Duct[®], 158,000 tdw Bulker, HSVA

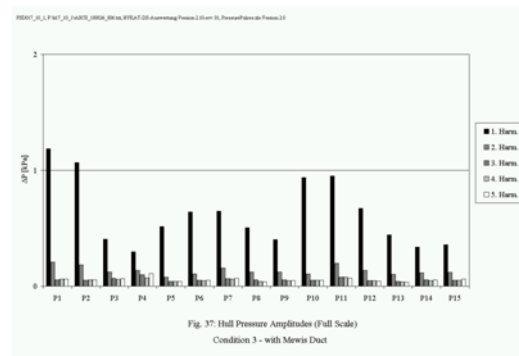

Figure 14: Pressure pulses above propeller with Mewis Duct[®], 158,000 tdw Bulker, HSVA

Figures 13 and 14 show measured pressure pulses at 15 holes in the model surface positioned directly above the propeller. The visual comparison of the graphs shows the significant decrease of the pressure pulses by the MD. The first blade frequency is reduced by 15 %, the second by 68 % and all higher frequencies by more than 80 %. These measurements are in line with the full scale observations regarding lower vibration levels.

8 MODEL SCALE MANOEUVRING TESTS

Model tests with and without Mewis Duct[®] were carried out at SSPA for a 46,000 tdw tanker. The ship without MD is slightly unstable in yaw. In this case, the MD resulted in a remarkable and unexpected improvement of the yaw stability. The first overshoot angle of the standardized Zig-Zag-Tests 10°/10° was reduced by 15 % and the second by 23 %, with the tactical diameter increased by only 3 %. In that special case, the IMO-criteria were fulfilled with the MD installed.

Table 1: Results of Manoeuvring Tests, 46,000 tdw Tanker, SSPA

46,000 tdw Tanker, SSPA				
Zig-Zag-Tests 10°/10°	IMO- Criterion	w/o MD	with MD	MD/ without
1st overshoot (°)	17,2	17	14,5	-15%
2nd overshoot (°)	31,8	40,6	31,4	-23%
Tactical diameter/Lpp	5	2,75	2,84	3%

9 INFLUENCE OF THE WAKE FIELD ON ACHIEVABLE IMPROVEMENTS BY MEWIS DUCT®

All energy saving devices work by reducing losses around the rotating propeller behind the ship.

The flow hitting the propeller is called the ship’s wake and can be simply portrayed as a so-called 3d-wake field, which is easy to measure in model tests or to estimate by CFD-calculations.

The axial component is generally caused by friction at the ship’s surface. The transverse components are caused mainly by the ship’s form, especially the curvature of the ship lines. The propeller is able to recover a part of the frictional energy present in the ship’s wake.

Pre-ducts (and partial pre-fins) reduce the losses within the transverse components of the wake field. Consequently, the efficiency of pre-ducts and pre-fins depends on the type of wake field, and in particular from the transverse flow losses in the wake.

The transverse components in the wake field are very different from ship form to ship form.

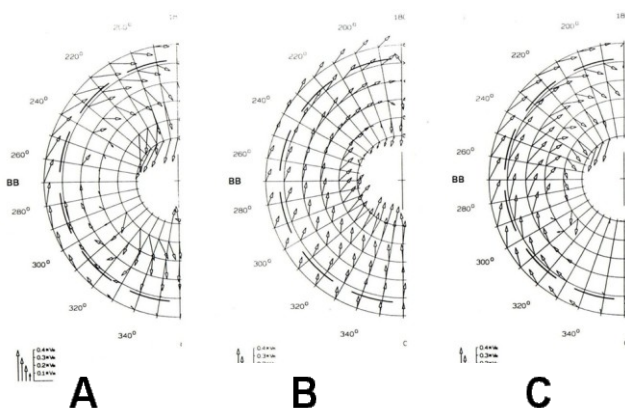

Figure 15: Different types of transversal wake fields

Figure 15 shows the three main types of transverse wake fields. Type A has a very large vortex, that is to say a high energy content. Type B has a much smaller vortex. Most ships are somewhere in between, as Type C shows. These vortices are so-called line vortices; they are created just aft of the midship section at the bilge region, for this reason they are also called bilge vortices.

These bilge vortices crucially influence the possible power savings by pre-ducts, and in addition, they have a large influence on the course stability and a moderate influence on the cavitation behaviour. Table 2 summarises these factors.

Table 2: Effect of Mewis Duct® depending on the intensity of the transverse vortex in the wake field

Types of transversal vortices in the wake field			
Vortex Type	A	B	C
Vortex Intensity	large	small	medium
Power savings by MD			
Ship resistance	high	low	medium
MD power reduction	high	low	medium
Course Stability improvement by MD			
Course Stability	sufficient	not sufficient	medium
Improvement by MD	low	medium	medium
Reduction of Pressure Pulses			
Reduction by MD	high	medium	high

Consequently, the intensity of the transverse vortex within the wake field influences the possible power reduction by the Mewis Duct®. In summary:

- Large vortex: 5 % - 10 % power reduction possible
- Small vortex: 1 % - 5 % power reduction possible
- Medium vortex: 3 % - 8 % power reduction possible

10 THE USE OF CFD IN THE MEWIS DUCT® DESIGN PROCESS

For every new ship project to which the Mewis Duct is applied, an individually designed and optimised Mewis Duct® is developed. This process is largely based on CFD-calculations in combination with model tests.

The CFD-calculations are performed by solving RANS equations on unstructured finite volume meshes. For the flow simulations the ship hull, rudder, propeller and duct are all modelled explicitly. Therefore, in order to design a Mewis Duct® for a given ship, it is necessary that geometry information for the ship’s hull and propeller, as well as main self-propulsion data for the contractually agreed design point, is made available.

The objective of the optimisation is to adjust the duct to the individual hull shape and wake characteristics, and to select a duct design that provides the highest possible power saving for the considered vessel. CFD-tools are ideally suited for this type of work because almost every flow detail that helps in the decisions of the design process can be relatively easily extracted from the simulations. As an example, Figure 16 shows the influence of the duct ring on the near wall flow for a recent project.

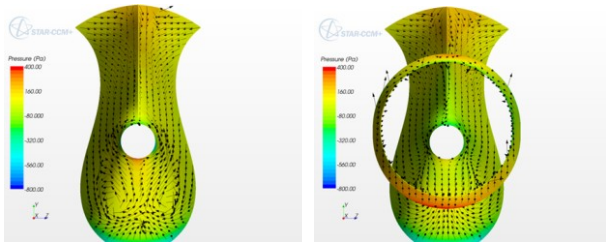

Figure 16: Near wall flow for a recent duct design without Mewis Duct® and with the duct ring only

In general, between 3 and 20 Mewis Duct® designs are studied by means of CFD-simulations before a decision on the final duct design is made, which is then further investigated in model tests. The final Mewis Duct® design might look quite different, depending on the ship it is designed for. The number of duct design iterations needed for each project has reduced noticeably with increased design experience.

The model tests serve mainly to determine the power saving achieved with the respective Mewis Duct® design. Additionally, the model tests are used for the optimisation of the fin pitch angles and as validation data for the CFD-calculations.

In order to ensure satisfactory performance of the Mewis Duct® at full scale, the final duct with the final optimised fin settings from the model tests is calculated in both full and model scale. In case substantial differences are observed, the fin settings are adjusted slightly. These adjustments are done with great care, since there are uncertainties associated with the correct prediction of the ships full scale wake.

For the purposes of reliably determining the power reduction achieved, prior to any sea trials, full scale predictions based on model tests seem to be the most adequate tool at the moment. As mentioned in Paragraph 4, a close agreement is found so far for predictions based on model tests and full scale measurements.

The accuracy of the CFD-calculations regarding the power reduction still shows a degree of scatter. In Figure 17, the power reduction measured in model tests and that predicted with model scale CFD-calculations is shown for the last 15 Mewis Duct® designs model tested as part of the last 9 Mewis Duct® projects. It can be seen that for 11 of the last 15 designs the CFD predicts the power saving achieved with an accuracy of $\pm 2\%$ of the absolute power value. Nevertheless, in some cases differences of up to 4% might occur. It should be noted that the differences observed are not purely related to flow modelling problems. Due to these projects all being commercial work, compromises have to be made with respect to time frames and ship information available.

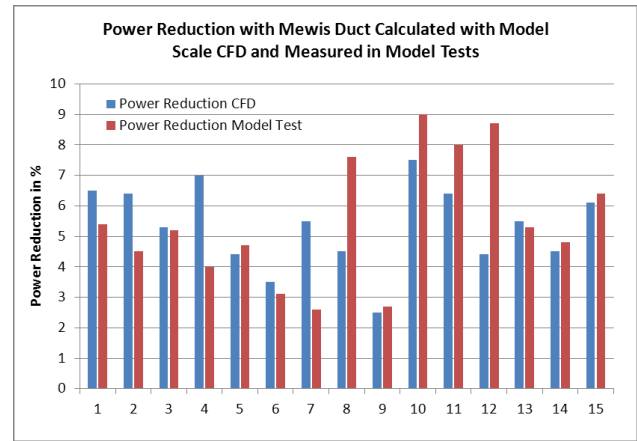

Figure 17: Determined power reduction with the Mewis Duct® based on CFD and model tests

11 CONCLUSIONS AND FUTURE DEVELOPMENTS

At the SMP09, the Mewis Duct® (MD) was introduced as a novel type of ESD in its first stage of development and realisation. Since then more than 16 MDs have been installed in different vessels, with more than 80 on order.

Model tests were performed for several projects in different tanks worldwide. In general, the results have been very successful: The MD not only reduces the required power by up to 8% with a mean saving averaged over 35 tests of 6.5%, but also significantly reduces the vibration excitation by reducing pressure pulses by up to 80%. Cavitation behaviour of the propeller is positively affected, and the MD tends to improve the course stability of unstable vessels.

Full scale measurements and observations regarding achieved power saving, cavitation and vibration observations correspond very well with model test results.

Based on 6% average power saving and 220 days/year operating time, the ROI (return of investment) is about one year, with an actual bunker price of 600 \$/t.

The Mewis Duct® is suited to ships whose propeller load C_{Th} is typically greater than 1.0 and speed less than 20 knots. Generally speaking, this encompasses small container vessels, small vessels with high block coefficient, multi-purpose carriers, all tankers and bulk carriers. Optimisation of the PSD is required on a ship-by-ship basis.

Modern CFD-techniques are used to assist in this process. The very stable and comparatively high power reductions by the Mewis Duct® are also a result of the consistent use of CFD-methods for optimisation of the whole device.

Future planned developments of the Mewis Duct® involve extending the design and optimisation process to include vessels faster than 20 knots, for example very large container vessels.

REFERENCES

- Andersen, P. Anderson, S. V. Bodger, L. Friesch, J. & Kappel, J. J. (2000). 'Cavitation Considerations in the Design of Kappel Propellers'. Proceedings of NCT'50, International Conference in Propeller Cavitation, 3-5, University of Newcastle, UK.
- Lee, J. T. Kim, M. C., Suh, J. C. Kim, S. H. & Choi, J. K. (1992). 'Development of a Preswirl Stator- propeller System for Improvement of Propulsion Efficiency: a Symmetric Stator Propulsion System'. Transaction of SNAK 29(4), Busan, Korea.
- Mewis, F. Peters, H.-E. (1986). 'Power Savings through a Novel Fin System'. 15. SMSSH Conference, Proceedings, Varna, Bulgaria.
- Mewis, F. (2009). 'A Novel Power-Saving Device for Full-Form Vessels'. First International Symposium on Marine Propulsors, SMP'09, Trondheim, Norway.
- NN, (2005). 'Hyundai Thrust Fin Improving Propulsion Efficiency'. Flyer, Hyundai Maritime Research Institute, Ulsan, Korea.
- Ouchi, K., Kawasaki, T. & Tamashima, M. (1990). 'Propeller Efficiency Enhanced by PBCF'. 4th International Symposium of Marine Engineering (ISME 90), Kobe, Japan.
- Sasaki, N. & Aono, T. (1997). 'Energy Saving Device "SILD"'. Journal of Shipbuilding 45(135), Japan.
- Schneekluth, H. (1986). 'Wake Equalising Ducts'. The Naval Architect 1986, London, UK.
- Van Lammeren, W. P. A. (1949). 'Enkele Constructies ter Verbetering van het Rendement van de Voorstuwing'. Ship en Werf van 1 April 1949 7, Rotterdam, The Netherlands.
- Wagner, R. (1929). 'Rückblick und Ausblick auf die Entwicklung des Contrapropellers'. Jahrbuch der Schiffbautechnischen Gesellschaft 30, pp. 195 – 256, Berlin, Germany.